

**Options & Accessories**



**Roll-Around™ Stands**

**PRODUCT CATALOG**

Magnatag<sup>®</sup>  
2031 O'Neill Rd  
Macedon, NY 14502

**Toll Free:** (800) 624 4154  
**Fax:** (315) 986 4000  
**Email:** sales@magnatag.com  
**Web:** www.magnatag.com



*How Do You Show  
what's Happening?*



Proudly manufactured  
in Macedon, NY





# MagnaLux® Framed Magnetic Dry-Erase Whiteboards



FabricTack®  
Blue



FabricTack®  
Gray

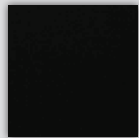

FabricTack®  
Black



CorkTack™



FabricTack®  
Sand



FabricTack®  
Green



FabricTack®  
Claret

ITEM	START DATE	DUE DATE	% COMPL	REV. DATE	ASSIGNEE	REMARKS

ITEM	DATE	GOAL DATE	NOTES

## 1. Features

- Magnalux® Porcelain-Like Steel Markerboards
- FabricTack® Fabric and Cork Tackboards
- 1-1/8" Wide Perimeter Trim
- Satin Anodized 6063 T-5 Tempered Aluminum Frame
- 1-1/8" Panel Thickness
- Maximum Width 13' (single steel max)
- Maximum Height 4' (single steel max)
- Meets ASTM E-84 with a Class A fire rating based on following results:  
Flame spread – 0; smoke developed – 50
- Complete details at [magnatag.com/WB](http://magnatag.com/WB)

## 2. Frame Styles

- 3 Frame Styles (Silver, Black, Cherry)
- Option for added TackStrip / Map Rail

## 3. FabricTack® and CorkTack™

- We offer a selection of 6 densely woven FabricTack® options or cork bulletin boards. Make a statement about the quality and efficiency of your organization when you use these boards to neatly display your documents, announcements, and notices.

## 4. Printed Board Systems

- Choose from over 2700 heat-fuse printed board systems to help you plan, schedule, organize, and communicate.

# INSTALLATION

## Safety Hooks

- Bail hangers are fastened on the back of the whiteboard every 16 inches to correspond to standard frame construction. Fasten Safety Hooks to wall studs at the desired height and loop bail hangers over hooks to mount your whiteboard.

## FrameKlamps™

- This option allows fine tuning your whiteboard location left to right when wall studs are not in an ideal location for board mounting. Once your board is in the desired location simply rotate the lever on the FrameKlamps™ to lock your whiteboard in position.
- FrameKlamps™ fasten top and bottom of board tightly to the wall and can be mounted horizontally or vertically.

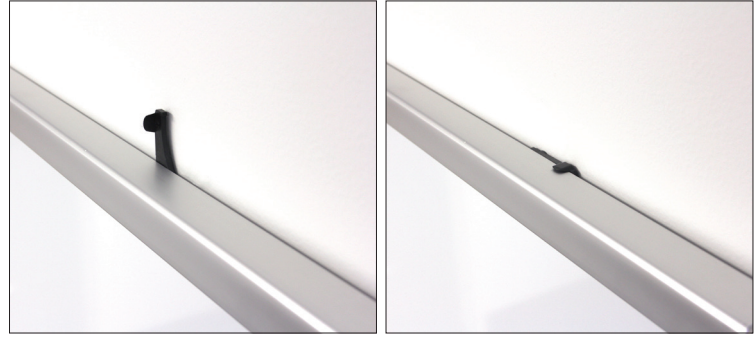
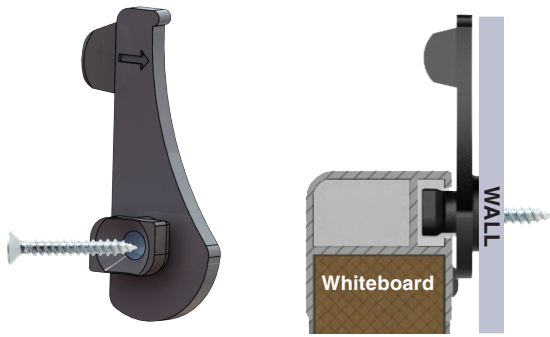

# ADDITIONAL OPTIONS

## PrivateEye™ Privacy Screen & Mounting Clips

- Keeps sensitive information out of plain sight
- Covers boards up to 8' wide and 4' high

## FileView® Wall Organizer Accessory

- Easily access important files with this 16 pocket (or 11 pocket for 3' boards) organizer
- Built into the BoldLyne® Frame
- Compatible with 3' and 4' tall boards
- 12" wide
- Matches BoldLyne® frame color

## Aluminum Accessory Tray

- Available in silver or black
- 5 lengths (2', 3', 4', 6', 8' wide)
- 1-1/4" tray depth
- Smooth contoured edge caps, no sharp edges
- Factory-installed (can be field added)

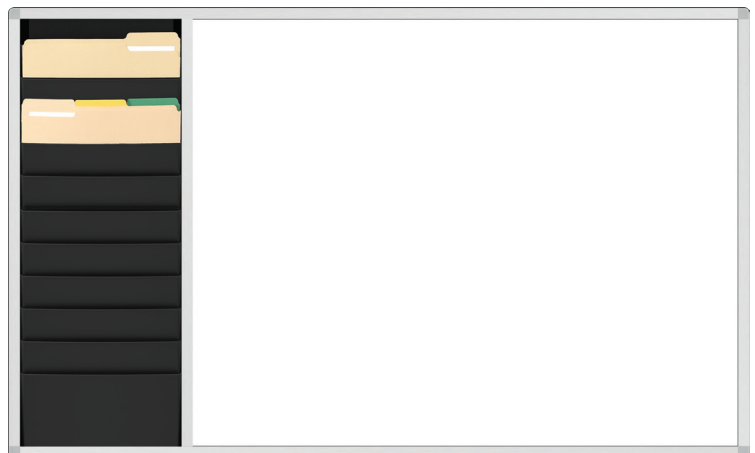
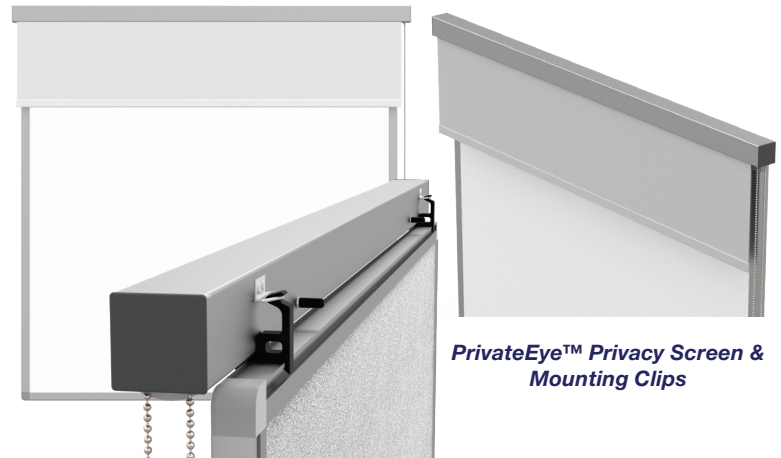

Aluminum Accessory Tray

FileView® Wall Organizer Accessory

# BOARD SPECIFICATIONS

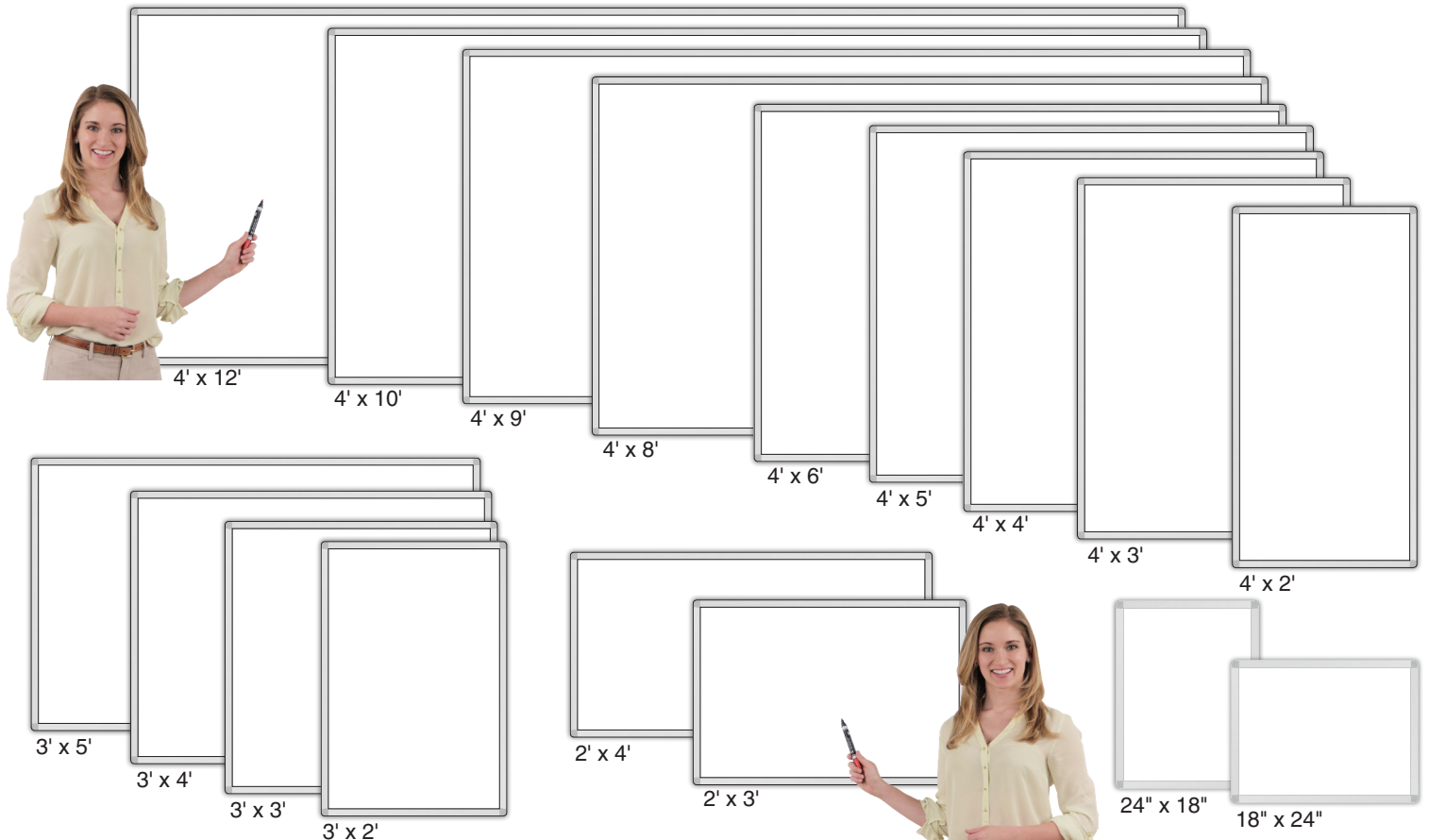

Listed Board Size (h x w)	Actual Board Size (h x w)	Working Area (h x w)	Weight (lbs.)
18" x 24"	19-1/2" x 25-1/2"	17" x 23"	5
24" x 18"	25-1/2" x 19-1/2"	23" x 17"	5
36" x 18"	37-1/2" x 19-1/2"	35" x 17"	8
2' x 3'	25-1/2" x 37-1/2"	23" x 35"	11
3' x 2'	37-1/2" x 25-1/2"	35" x 23"	11
2' x 4'	25-1/2" x 49-1/2"	23" x 47"	13
4' x 2'	49-1/2" x 25-1/2"	47" x 23"	13
3' x 3'	37-1/2" x 37-1/2"	35" x 35"	15
3' x 4'	37-1/2" x 49-1/2"	35" x 47"	19
4' x 3'	49-1/2" x 37-1/2"	47" x 35"	19
3' x 5'	37-1/2" x 61-1/2"	35" x 59"	22
4' x 4'	49-1/2" x 49-1/2"	47" x 47"	24
4' x 5'	49-1/2" x 61-1/2"	47" x 59"	32
5' x 4'	61-1/2" x 49-1/2"	59" x 47"	32
4' x 6'	49-1/2" x 73-1/2"	47" x 71"	37
6' x 4'	73-1/2" x 49-1/2"	71" x 47"	37
4' x 7'	49-1/2" x 85-1/2"	47" x 83"	43
4' x 8'	49-1/2" x 97-1/2"	47" x 93"	48
4' x 9'	49-1/2" x 109-1/2"	47" x 107"	53
4' x 10'	49-1/2" x 121-1/2"	47" x 119"	59
4' x 12'	49-1/2" x 145-1/2"	47" x 143"	71

# BOLDLYNE® X-SECTION



Frame Styles (Silver, Black, Cherry)

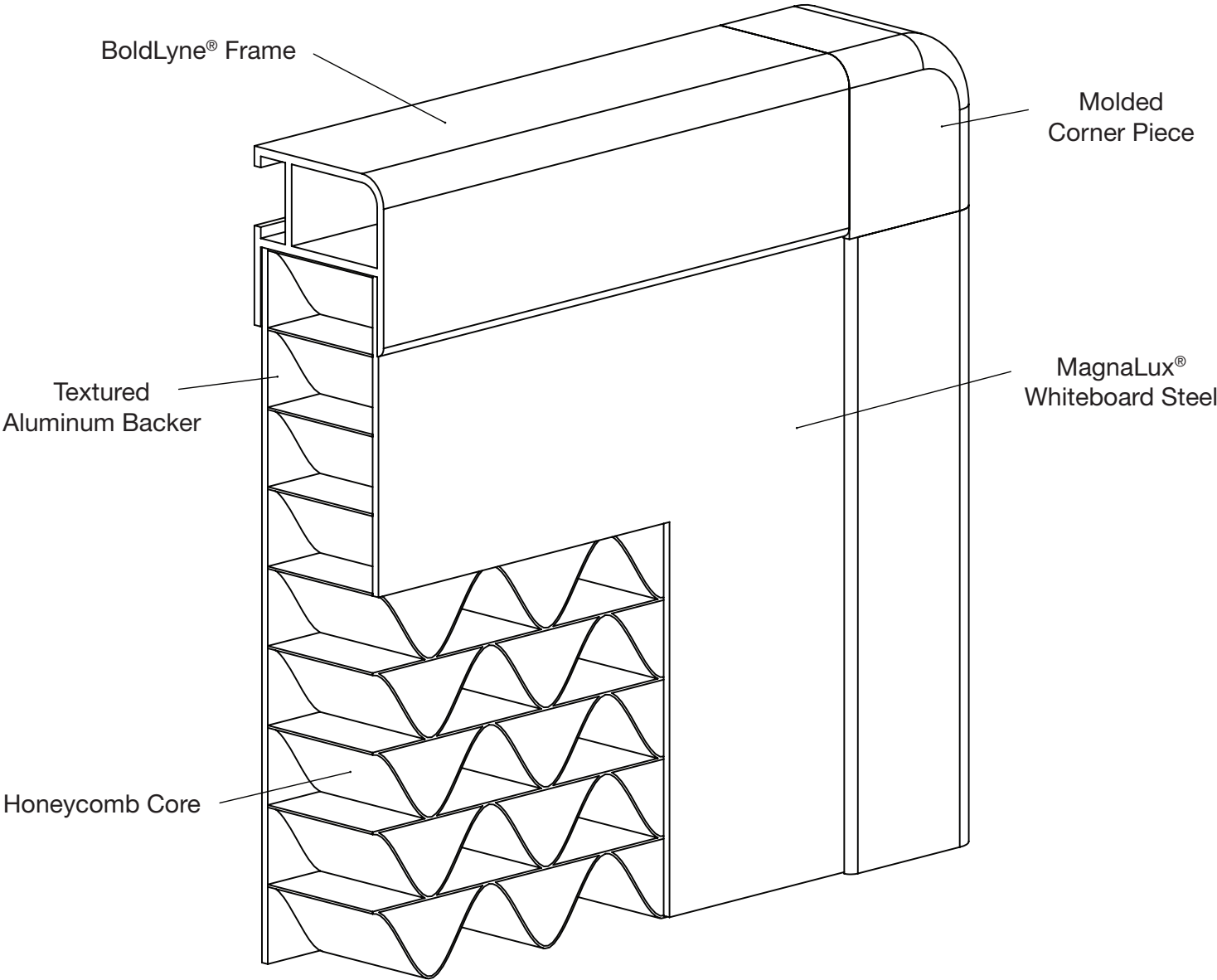



# Roll-Around™ Magnetic Whiteboard Stands



- FabricTack® Colors**
- |   |   |
|---|---|
|    |    |
| Sand  | Blue  |
|  |  |
| Green   | Black   |
|  |  |
| Claret  | Gray  |

**Magnatag® Roll-Around™ Stand**  
Foot Assembly Instructions

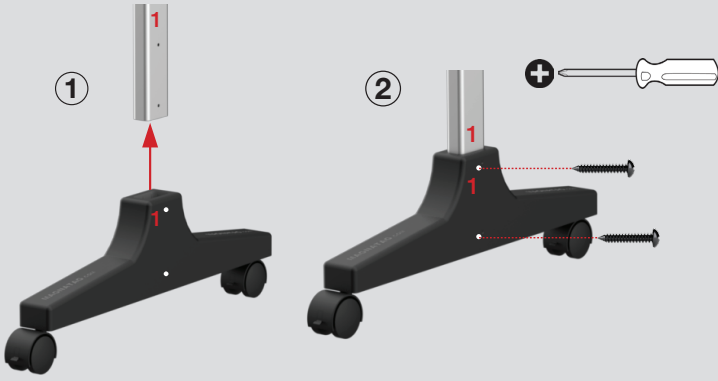

## 1. Features

- Magnalux® Porcelain-Like Steel Markerboards
- Rolls around easily, does not pivot
- Includes 4 locking casters and aluminum marker tray
- All Roll-Around™ Stands are 79" tall
- The stand feet are 24" long x 2" wide. Stand foot height from the floor is 7" (at leg) and 3-1/2" (at wheels)
- Complete details at [magnatag.com/ZV](http://magnatag.com/ZV)

## 2. Options

- Available dual or single-sided, plain white or choose from over 2700 printed panel options
- Order your whiteboard stand with an open base (pictured above) or with a fabric decor base panel (in any of our FabricTack® colors)
- Any BoldLyne® framed whiteboard up to 8' wide can be built on a steel Roll-Around™ Vertical Whiteboard Stand

## 3. Assembly

- Caster wheels require minor assembly (see diagram to the left)

# Roll-Around™ Horizontal Pivoting Whiteboard Stand

## 1. Features

- Magnalux® Porcelain-Like Steel Markerboards
- Order with plain or printed magnetic whiteboards
- Rotates and locks into the vertical position with a snap release
- Includes 4 locking casters
- All Roll-Around™ Stands are 79" tall
- The stand feet are 24" long x 2" wide. Stand foot height from the floor is 7" (at leg) and 3-1/2" (at wheels)
- Complete details at [magnatag.com/ZH](http://magnatag.com/ZH)

## 2. Options

- Order your whiteboard stand with an open base or with a fabric decor base panel (in any of our FabricTack® colors)
- Available in 4 sizes: 3'x4', 4'x4', 4'x6', 4'x8' (hwxw)

## 3. Assembly

- Caster wheels require minor assembly (see diagram on the opposite page)



# 4-Leg Safety Easel for Whiteboards

## 1. Features

- Significantly lowers the risk of collapse when compared to traditional 3-leg whiteboard easels
- 4 legs that lock in place
- Heavy duty satin aluminum structure
- Designed for use with our magnetic whiteboards up to 4'x6' wide
- Larger boards can be supported with two easels
- Adjustable viewing height for smaller boards
- Folds for easy transport
- Complete details at [magnatag.com/ESL](http://magnatag.com/ESL)