

TrackWall® Sliding Panel FullWall® System Assembly Instructions

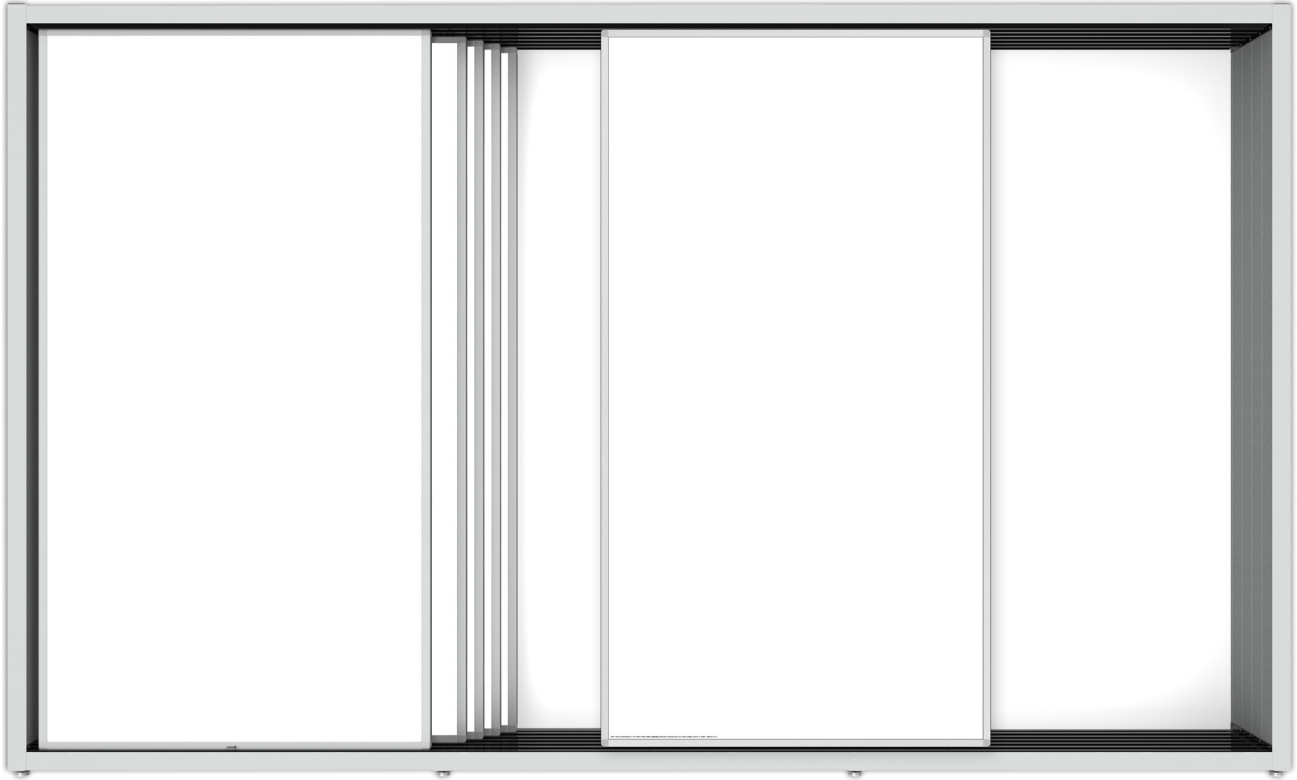

Cabinet Components & Hardware

- 2 Crossmembers, upper and lower (with attached adjustable feet)
- 2 Uprights, left and right (with attached adjustable feet)
- Whiteboard Back Panels
- Wall Mount ("L") Brackets
- #8 - 1" Black Pan Head Screws
- #8 - 1" Silver Pan Head Screws
- #8 - 1-3/4" Silver Pan Head Screws

Assembled Cabinet Dimensions

Sliding Panels

- | | |
|---|--|
| <input type="checkbox"/> Plain White | <input type="checkbox"/> 1" Square Grid |
| <input type="checkbox"/> 1-1/4" Rows | <input type="checkbox"/> 1" Square Ghost-Grid™ |
| <input type="checkbox"/> 1-1/4" Ghost-Rows™ | <input type="checkbox"/> TackFree® Fabric |
| <input type="checkbox"/> 1" ShadeLine® Rows | <input type="checkbox"/> FabricTack® |
| <input type="checkbox"/> 6-1/2" Columns | <input type="checkbox"/> CorkTack™ |
| <input type="checkbox"/> MapMount® System | <input type="checkbox"/> Other: _____ |

Tools Needed

- Level
- Drill
- Framing Square
- Phillips Screwdriver (Low Profile or Stubby)

Item ID: TWA
Reorder: magnatag.com/twa

2902-2000-003



2031 O'Neill Road
Macedon, NY 14502-8953 USA
E-mail: info@magnatag.com
Web: magnatag.com/twa
Phone: 800 624 4154
Fax: 315 986 4000

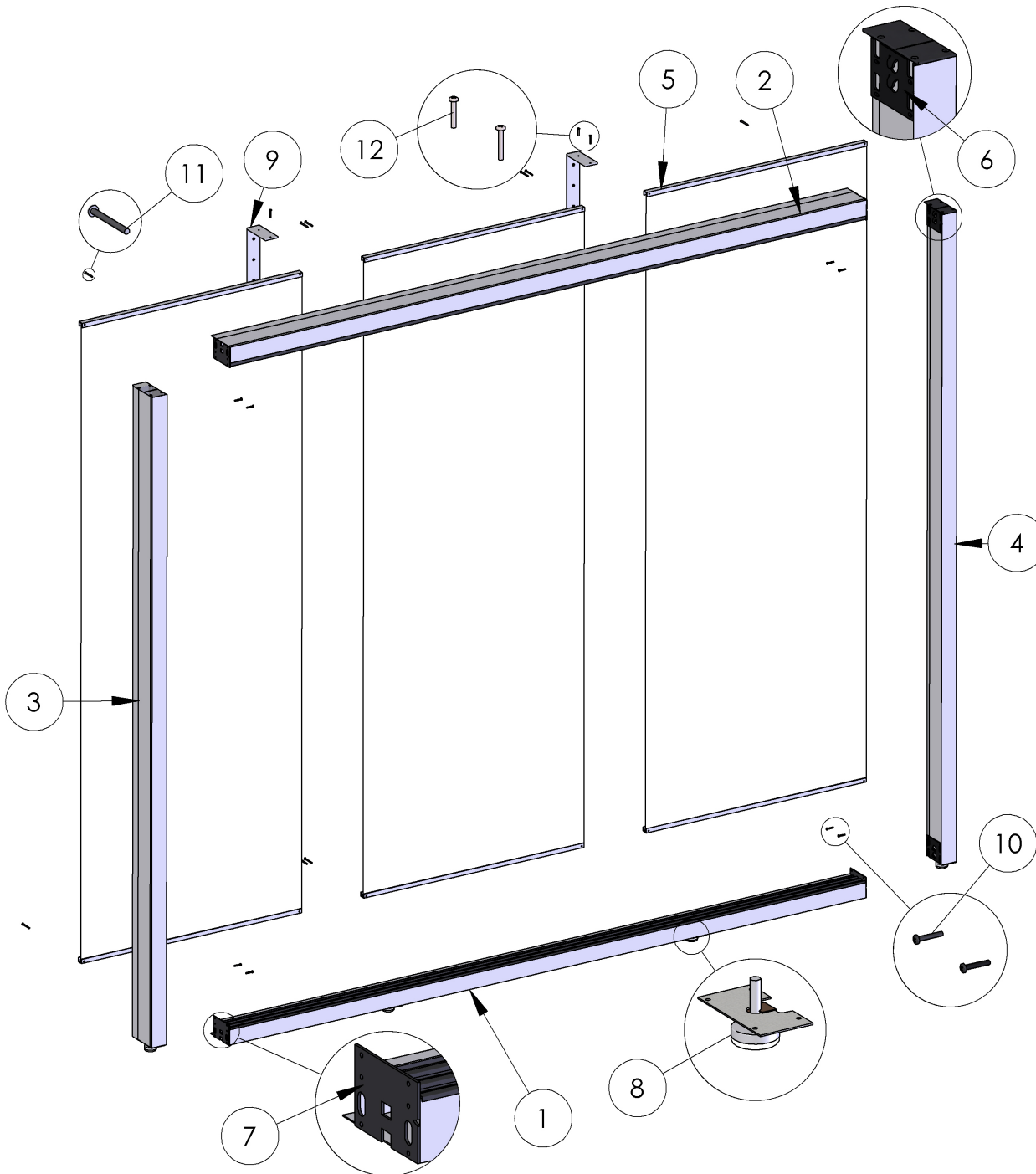
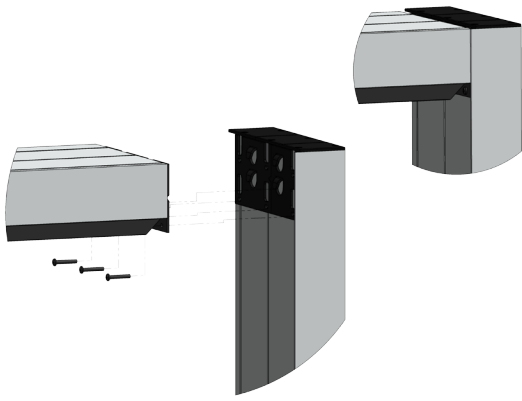

Diagram #	Part Description
1	Lower Crossmember
2	Upper Crossmember
3	Left Upright
4	Right Upright
5	Back Panels
6	Upright Endplate
7	Crossmember Endplate
8	Adjustable Feet
9	Wall Mounts / "L" Brackets
10	#8 Black Panhead screw, 1"
11	#8 Silver Panhead screw, 1-3/4"
12	#8 Silver Panhead screw, 1"

Assemble TrackWall® Cabinet face down on the floor near final installation location.



Step 1:

Attach upper crossmember* (2) to the uprights (3, 4) by sliding the upright endplates (6) over the crossmember endplates (7) as shown in figure . Repeat process for lower crossmember (1).

*Note: The upper crossmember has the deeper black SlidePanel™ tracks.

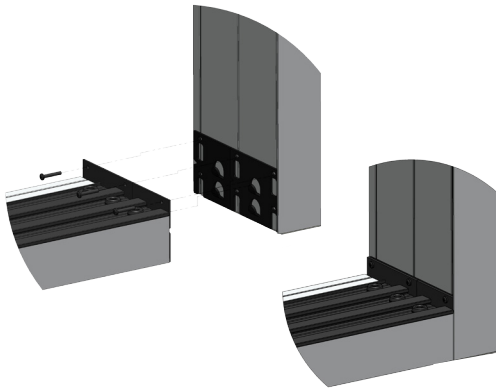

Step 2:

After squaring the assembled cabinet frame with a framing square, fasten the #8 1" black panhead screws (10) through the crossmember endplates (7) and into the upright endplates (6) for all four corners of the cabinet frame.

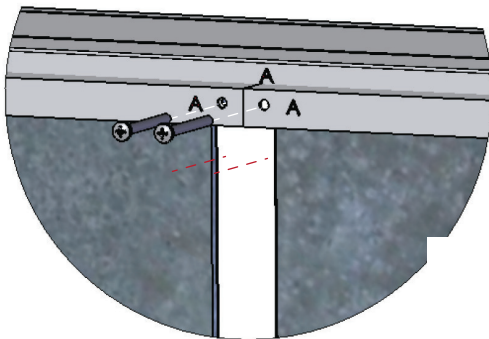

Step 3:

Install the cabinet Back Panels (5). Locate the letters on the back of the back panels and match with the letters on the assembled cabinet frame. Install back panels with whiteboard side down (toward front of cabinet). Fasten the back panels with the #8 1-3/4" silver panhead screws (11) into the pre-drilled holes on the cabinet frame.

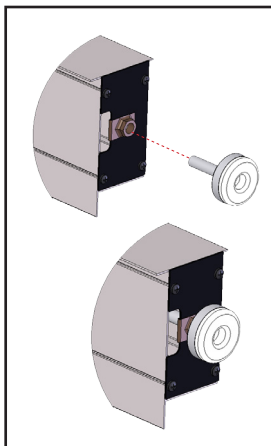

Step 4:

Insert Adjustable Feet (8) into the brackets at the bottom of the uprights and bottom crossmember. Turn all the way in before standing the unit up and then adjust as needed to level to your floor.

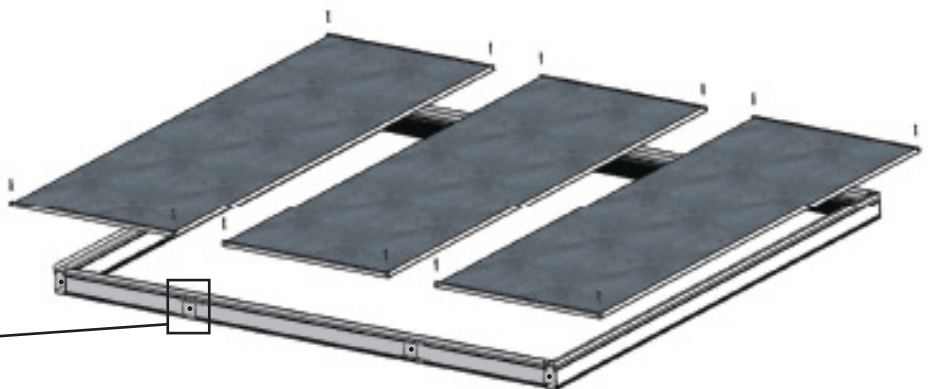

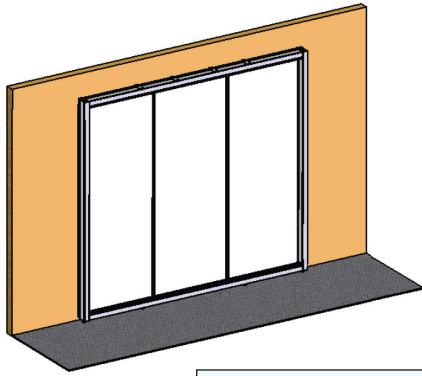

Step 5:

With the help of one or more people as needed, lift the assembled cabinet and position against desired wall location. Level the unit to the floor by turning the adjustable feet (8) as needed. Once leveled, place wall mount “L” brackets (9) over the upper crossmember (2) and slide down behind the cabinet (Fig. 4a). Position the L brackets at wall studs (if possible) and mark the locations of the brackets on the wall*. Also mark the drill hole locations through the L Bracket on crossmember (Fig. 4b), see **note**** below for high ceiling clearance installations.

***Note:** Be sure that the upper crossmember is level along the entire length of the cabinet when you mark your wall locations for the L brackets.

Setting & Marking Wall Mount Brackets

Position L Bracket (step 5)

Fig. 4a

Mark Wall and Cabinet (step 5)

Fig. 4b

Pre-Drill Top Crossmember (step 6**)

Fig. 4c

****Note:** If ceiling clearance allows, you can drill and fasten the L brackets into the top crossmember in step 7 below, no pre-drilling necessary.

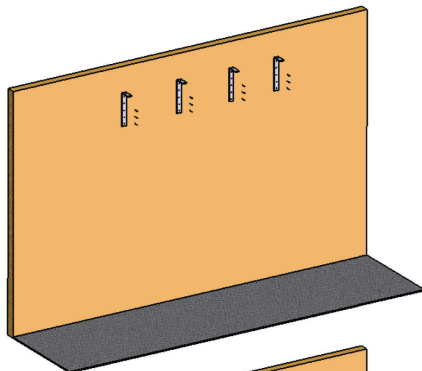

Step 6:

After wall and top crossmember (2) are marked, carefully remove the cabinet from the wall and set aside. Fasten the wall brackets (8) to the wall at marked locations using hardware appropriate for your wall type (not included). Be sure they are level. Next, pre-drill marked L bracket screw hole locations on top crossmember (Fig. 4c). For installations with minimal ceiling clearance, it may be necessary to lay the cabinet back down on the floor to enable pre-drilling of the top crossmember.

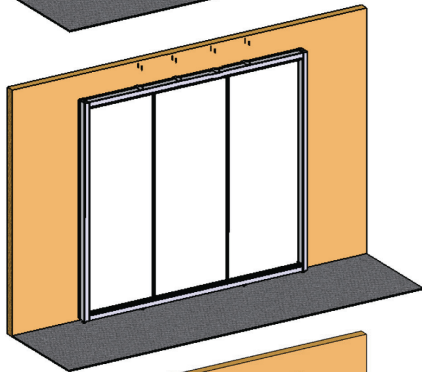

Step 7:

Place the unit back into position on the wall, sliding carefully under the installed L brackets. Be sure that the pre-drilled holes in the top crossmember line up with the screw holes in the L bracket. Using a Phillips Screwdriver (low profile or stubby type, depending on ceiling clearance), fasten the cabinet to the L brackets using the #8 1” silver panhead screws provided (12).

If ceiling clearance allows, you can pre-drill and fasten the L brackets to the cabinet during this step.

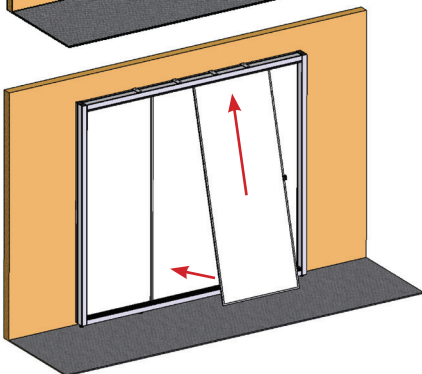

Step 8:

Load your sliding TrackWall® panels into the cabinet by inserting the top edge of the panel into the desired upper track at similar angle shown left. Pivot the panel into the cabinet so that the bottom edge of the panel is above the corresponding bottom track and let the panel seat downward into the bottom track. The panel should slide easily in the cabinet left to right. Repeat for all other panels. Your TrackWall® Cabinet is now ready for use.